

REV	DESCRIZIONE	DATA	Firma
A			

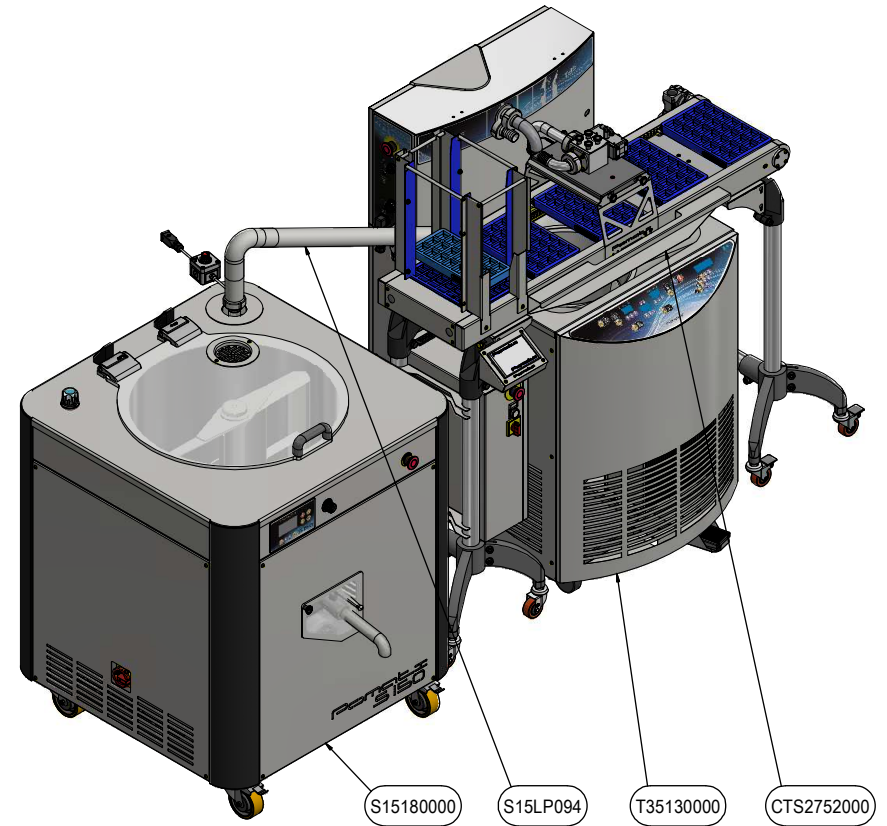
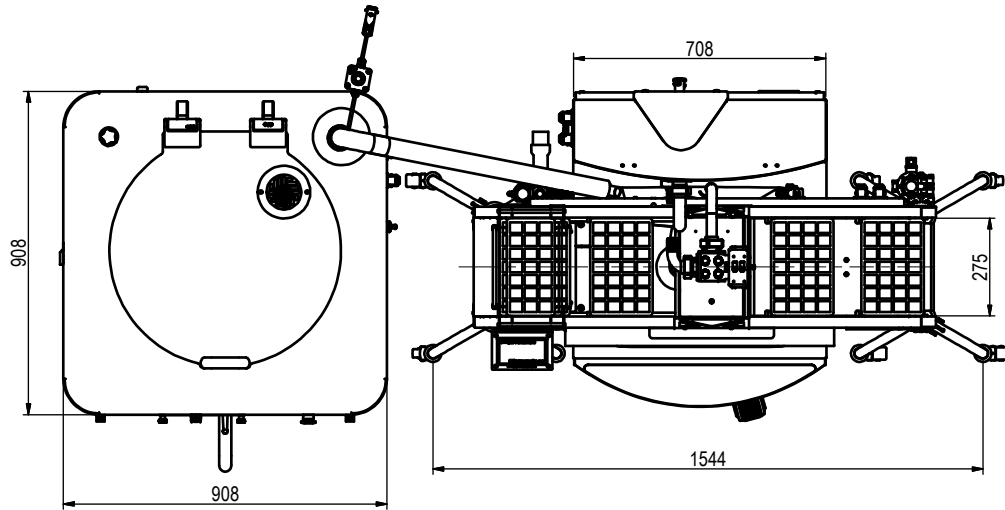
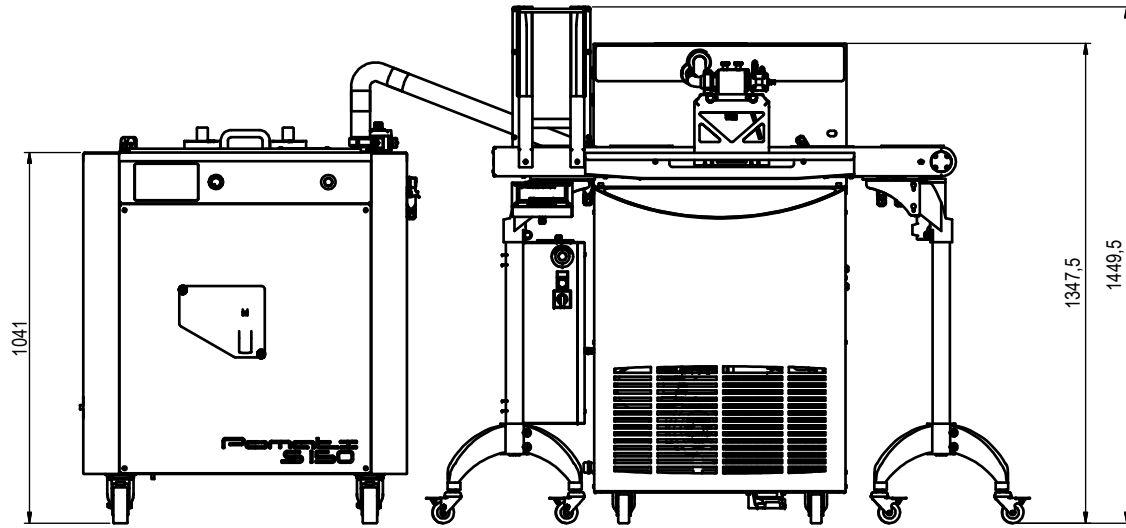

Pomati Group Russia  
Санкт-Петербург  
Москва  
www.pomati.net

ООО "Помати Групп Рус"  
+7(812) 456-58-48  
+7(499) 272-62-50  
info@pomati.net

<b>QUOTE SENZA INDICAZIONE DI TOLLERANZA: GRADO DI PRECISIONE MEDIO UNI 5307-63</b> <b>Measures with unspecified tolerances according to UNI5307-63</b>		SCOSTAMENTI PER DIMENSIONI ANGOLARI GRUPPI DIMENSIONALI LATO CORTO		FILET:	<b>TRATTAMENTI TERMICI - Thermal treatments</b>												
GRUPPO DIMENS.	0e8	e830	30e120	120e1315	1315e11000	1000e2000	2000e4000	>4000	15	3e6	6e30	30e120	>120	6H	ISO E	<b>TRATTAMENTI SUPERFICIALI - Surface treatments</b>	
DIM. LINEARI	±0.1	±0.2	±0.3	±0.5	±0.8	±1.2	±2	±3	±6	±1*	±30*	±20*	±10*	±10*		<b>FORNITORE Supplier:</b>	
ALBERI e FORI	0.2	0.4	0.6	1	1.6	2.4	4	6	10	15	20	30	50	80		<b>POMATI</b>	
SMUSSI NON QUOTATI Not dimensioned chamfers	RACCORDI NON QUOTATI Not dimensioned chamfers		QUOTE SENZA INDICAZIONE DI TOLLERANZA Measures with unspecified tolerances ISO 2768		<b>NB. Eliminare bave e spigoli vivi</b>												
SOSTITUITO DA - Replaced by:	DATA - Date	SOSTITUISCE IL - In the place of:		DATA - Date	DIS - Draft man	DATA - Date	VER. - Inspect by	DATA Rev. - Date	Rev.:								
					RR	14/07/2021				<b>MATRILE - Material:</b>		MASSA/Mass (Kg) Area (mm <sup>2</sup> )		N/A N/A			
<b>DEMINOIAZIONE - Description:</b> LAYOUT S150+T35+CTS																	
<b>CODICE DISEGNO - Drawing code:</b> LAYOUT0277																	
Pag.: 1 Rev.: 1 SCALA Scale																	



15	CTS2752000		CARICATORE STAMPI CON PIASTRA DOSAGGIO 275X175		1
16	S15LP094	A	TUBO USCITA CIOCCOLATO RISC. L=800MM		1
13	S15180000		SCIOGLITORE S150 CON POMPA 400V 50Hz		1
14	T35130000		TEMPERATRICE T35		1
Pos.	Cod. Parte	Rev.	Descrizione	MATERIALE	Q.tà

Proprietà riservata. Sono vietate la riproduzione totale o parziale, la comunicazione a terzi del presente progetto e di ogni piano, disegno e calcolo ad esso relativo. In caso di trasgressione la POMATI Group procederà ai sensi di legge.  
 This project is an exclusive property of POMATI GROUP. The owner prohibits its partial or total reproduction as well as disclosure to third party of the project itself and of any relevant plane, drawing and calculation. Any violation will be pursued by POMATI Group as by law enacted